



NEW ENERGY
新能源 NEW
GENERATION
2026 新世代

全港一年一度的中學生太陽能車比賽盛事

Smart Small Solar car, Solar boat & Glider Workshop 1
Print the Future

NENG2026



Briefing

簡介會

13/12/2025



Rideable solar car workshop

可載人太陽能車(大車)

工作坊, 共5場

31/01/2026

28/02/2026

14/03/2026

23/05/2026

04/07/2026

Online technical support session

技術支援 網上直播

25/07/2026

到校拜訪 Team visit

7月底及8月

初



Smart Small Solar car, Solar boat and glider workshop

智能遙控太陽能車(細車),
氫能車, 太陽能船及滑翔機

工作坊, 共3場

28/02/2026

23/05/2026

04/07/2026

場地練習

Venue practices

15/08/2026



Scrutineering

可載人太陽能車(大車)
車檢日

26/09/2026



Semi final

大車初賽

17/10/2026

Final

大車決賽

31/10/2026

Key Date	Event
28/02	Distribution of Competition Regulations
Before 28/02	Recruitment of team members and event registration
After 28/02	Prepare the procurement list and assign tasks to team members for collaboration
April	Easter Holiday – Work Commences (I)
July to August	Summer Holiday – Work Commences (II)
15/08	Venue practice
31/10	Final

Smart Small Solar car, Solar boat & Glider



Topic

- Introduction to Electric Vehicles
- Discussion on Current 3D Printing Technology
- Considerations in Chassis Design
- Power System for Small Vehicles

Introduction to Electric Vehicles

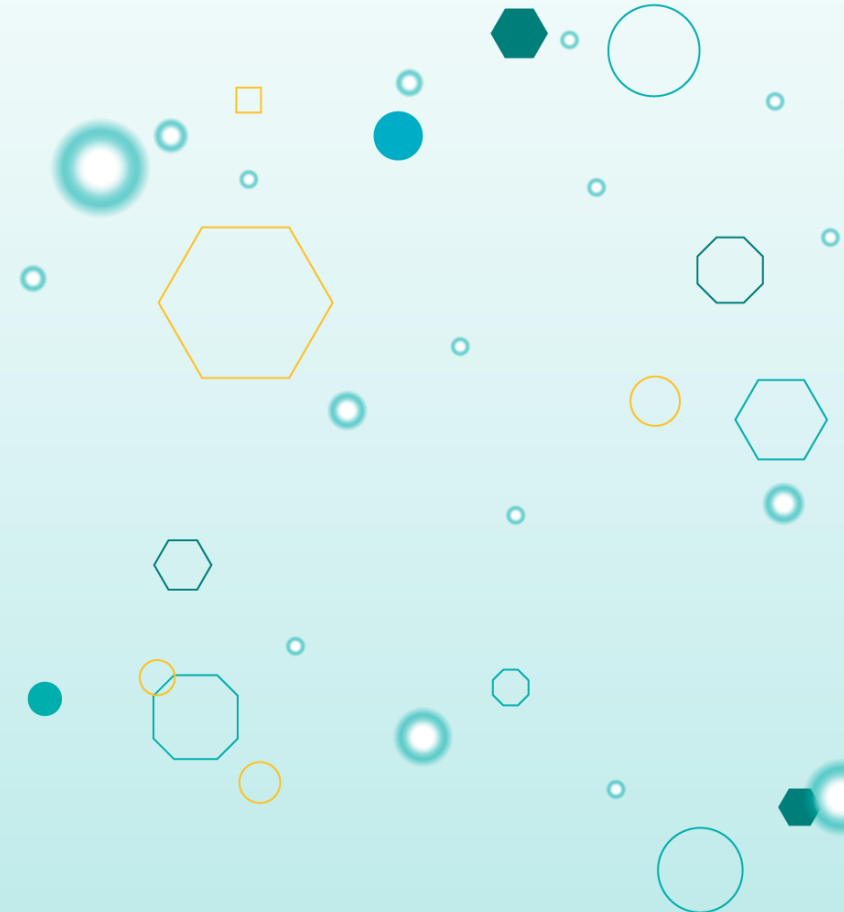

EV background



Power Sources
Electric vehicles will be powered by energy from traditional and renewable sources like solar, wind.

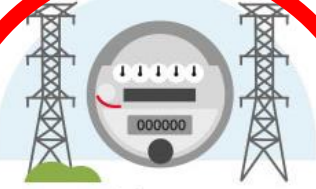

Smart Grid
A smarter grid will transmit information between utilities and charging stations, helping to create additional capacity, and enabling consumers to manage vehicle charging costs.



Infrastructure
GE provides infrastructure solutions, like transformers, submeters, and load centers, that support the roll-out of electric vehicles.



Commercial Charging Stations
Charging Stations will be available on city streets, retail destinations and other parking facilities.



Home Charging Stations
While you can plug an EV into any standard household 120V outlet, you'll get a significantly faster charge and optional internet connectivity if you install a charger like GE's WattStation.



Lightweight Materials
Automotive design have made EVs more powerful and efficient than ever.



Financing Solutions
GE Capital will provide solutions for businesses to finance electric vehicles for their fleets.



Better Batteries
Enable longer ranges with decreased charging times.



Reduced Emissions*
EVs can reduce CO2 emissions over 30% given the current US grid mix.



Up to 100 Miles On A Full Charge
A full charge with a Level 2 charger like GE's Wattstations takes 4-8 hours and can take a car for up to 100 miles.

*Source: EDTA (Electric Drive Transportation Association)



Pros and cons of EV

Advantages

- Zero pollution: No exhaust emissions during operation, which is beneficial to environmental protection
- High efficiency and energy saving
- Energy diversification
- Zero noise during operation

Disadvantages

- Heavy weight due to large batteries
- High initial cost
- Limited driving range
- Long charging time
- Incomplete supporting facilities: lack of charging infrastructure

Discussion on Current 3D Printing Technology



3D print technology

The first 3D printer was released in 1987 by Chuck Hull of 3D Systems. It used stereolithography (SLA) technology. [2]

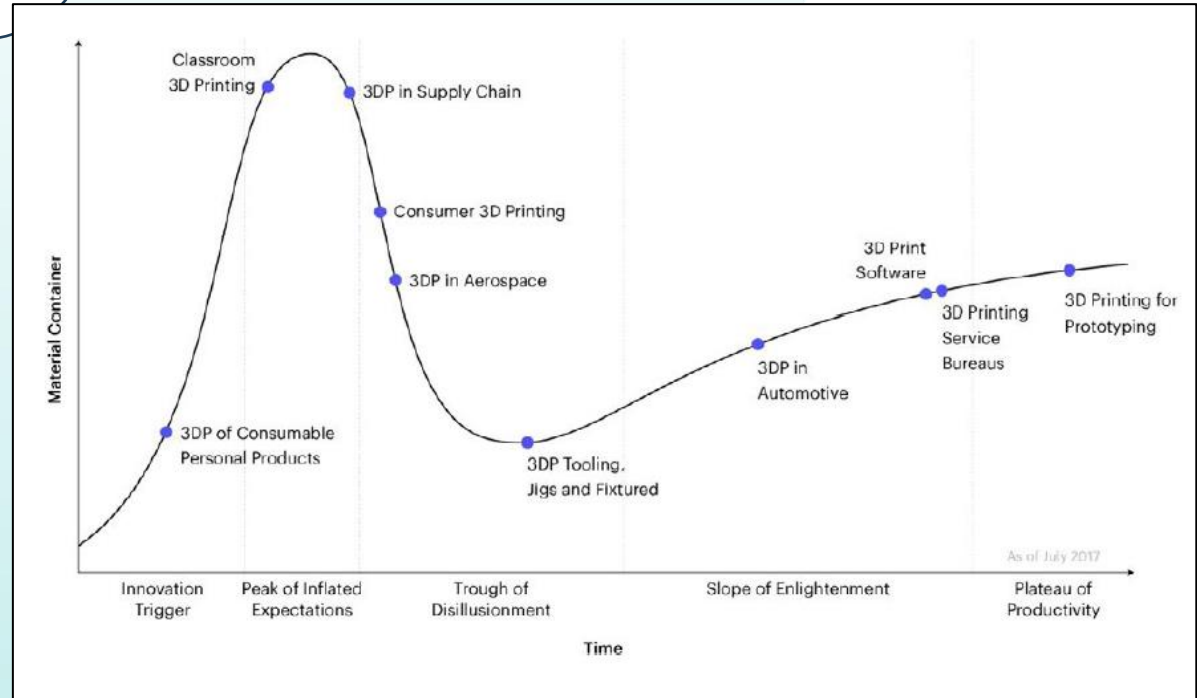
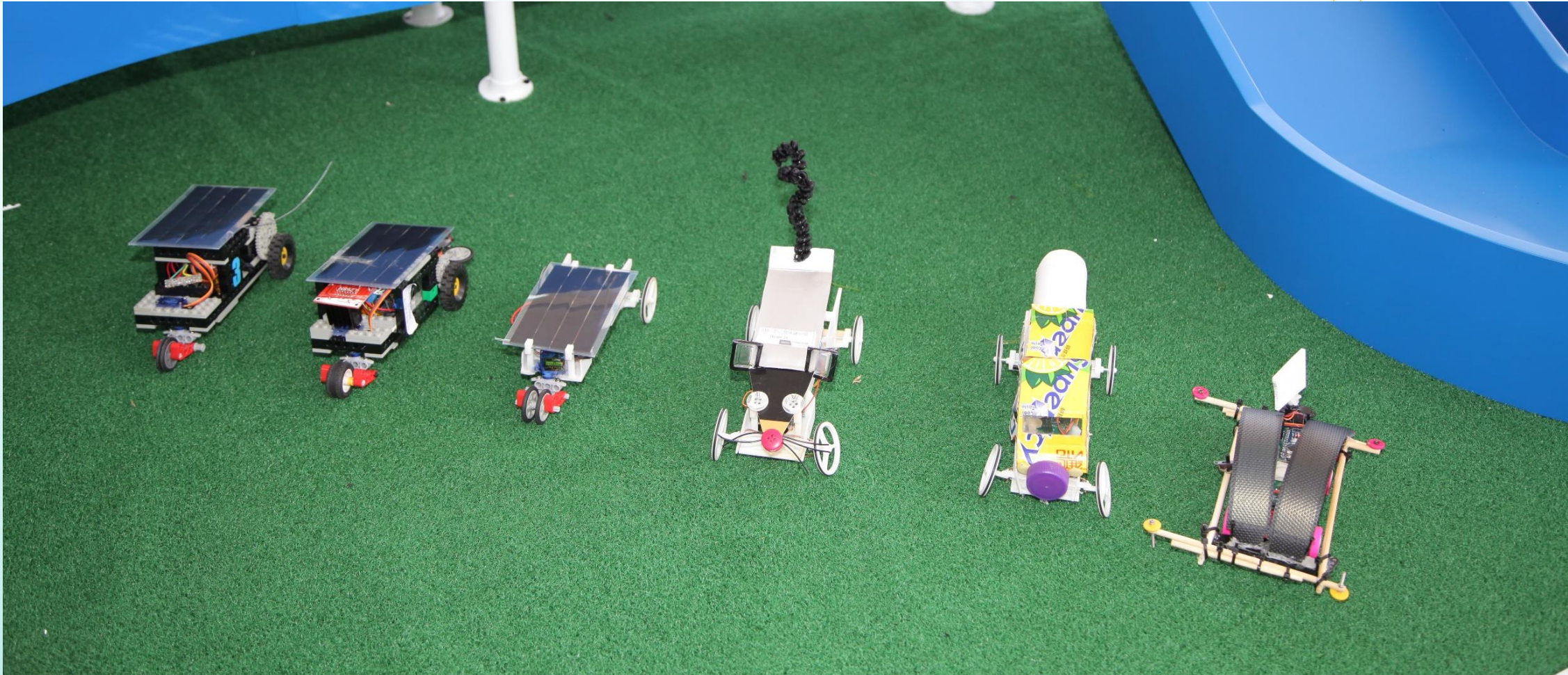

Fig.1 3D printing: beyond the hype [2]



3D print technology





3D print technology

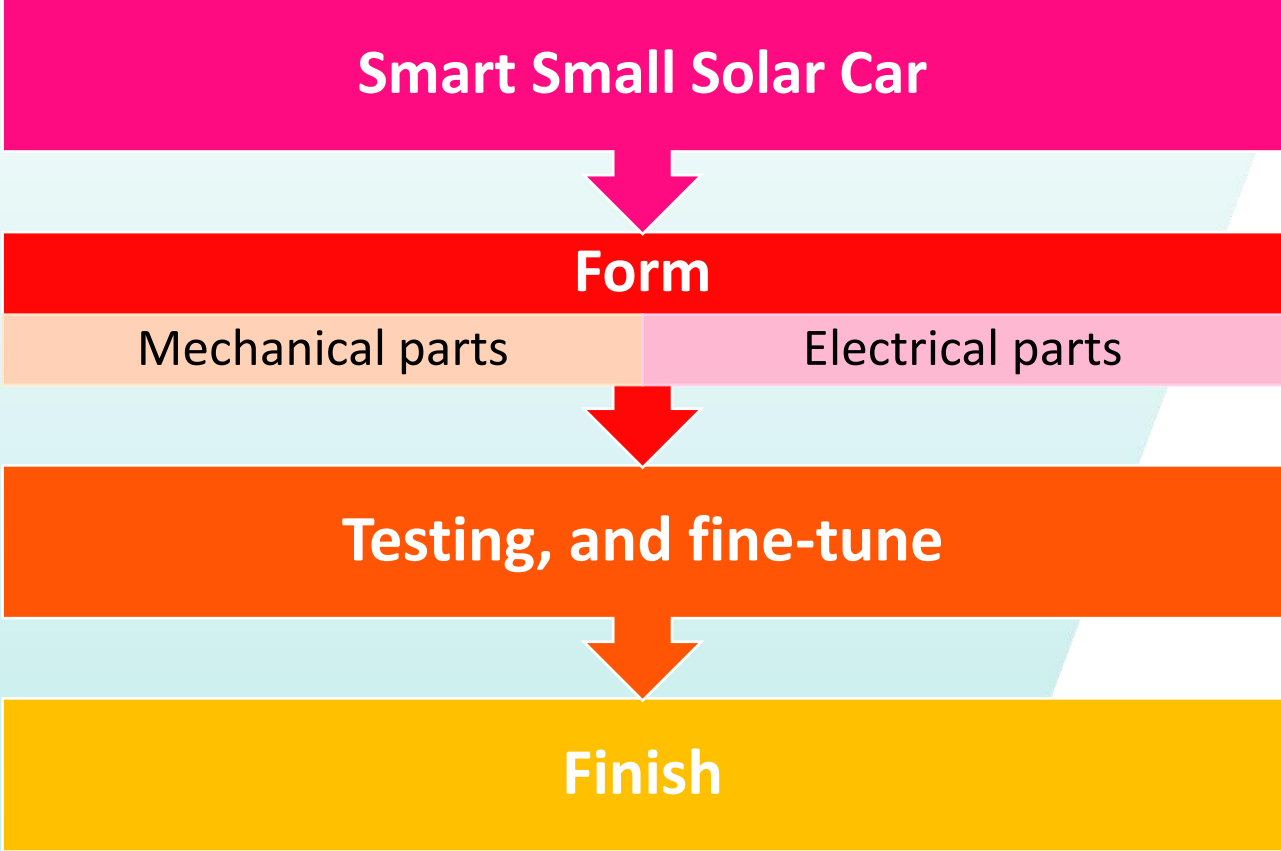

Design considerations

- Body dimensions
- Body shape
- Components and parts
- Operating principle

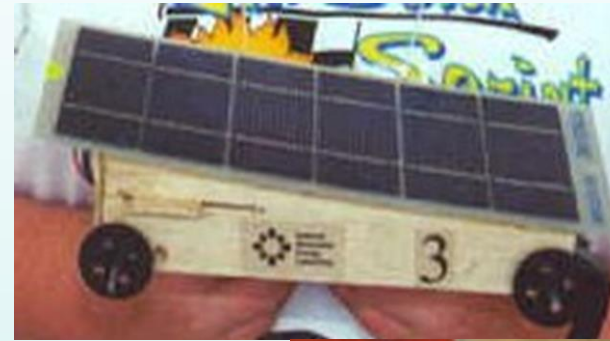



3D print technology

Traditional 3D printing methods:

- Machines are usually relatively large
- High cost of equipment and materials
- Difficult to operate





3D print technology

Current 3D printing methods:

- Smaller machine size
- Greatly reduced cost of materials and machines
- Easier to operate

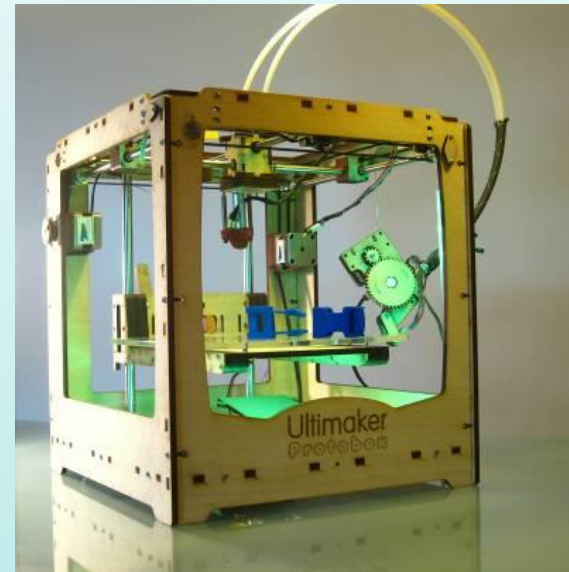



3D print technology

- Working guidelines
- Types of printing materials
- Types of 3D printers
- 3D printing software



3D print technology

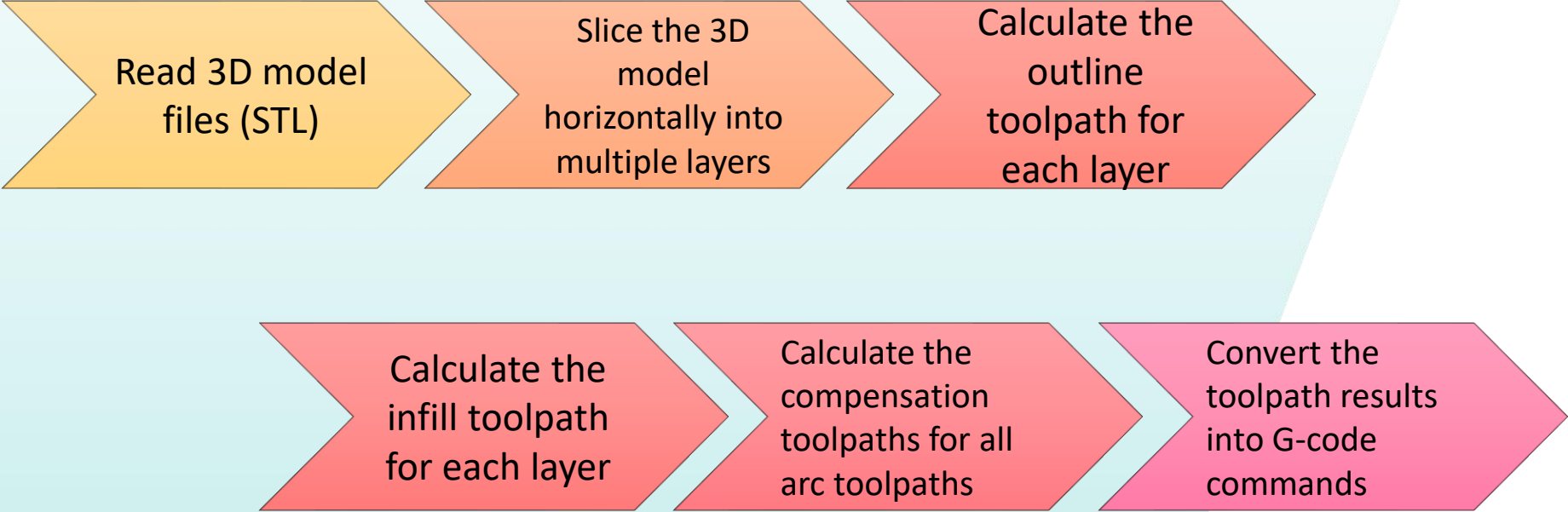



3D print technology

FDM 熔融沉積成型 (Fused Deposition Modeling)

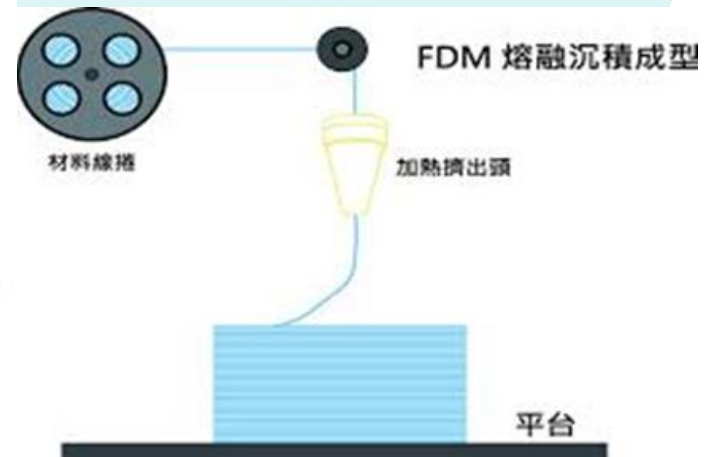
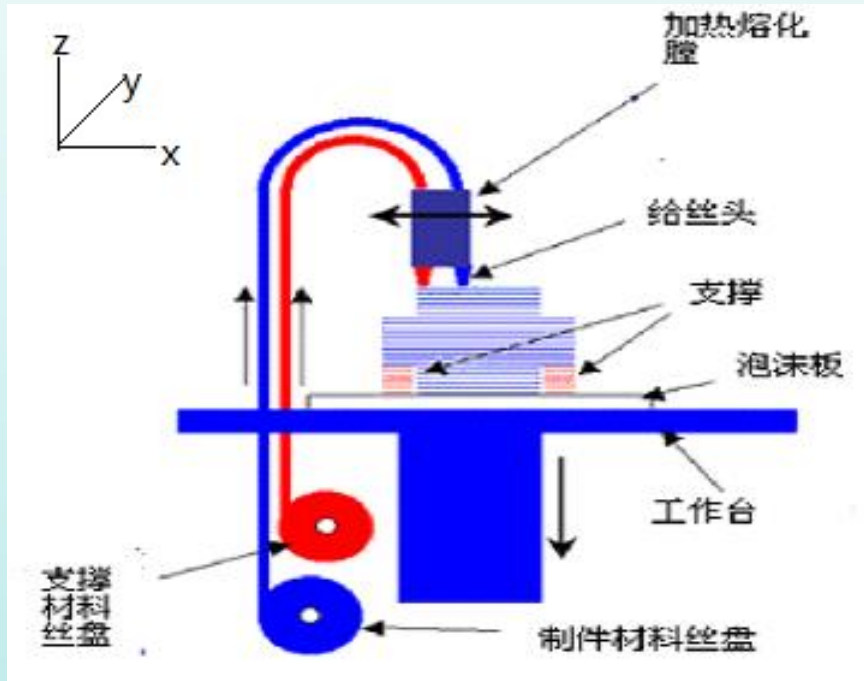

3D print technology

7種3D列印技術比較

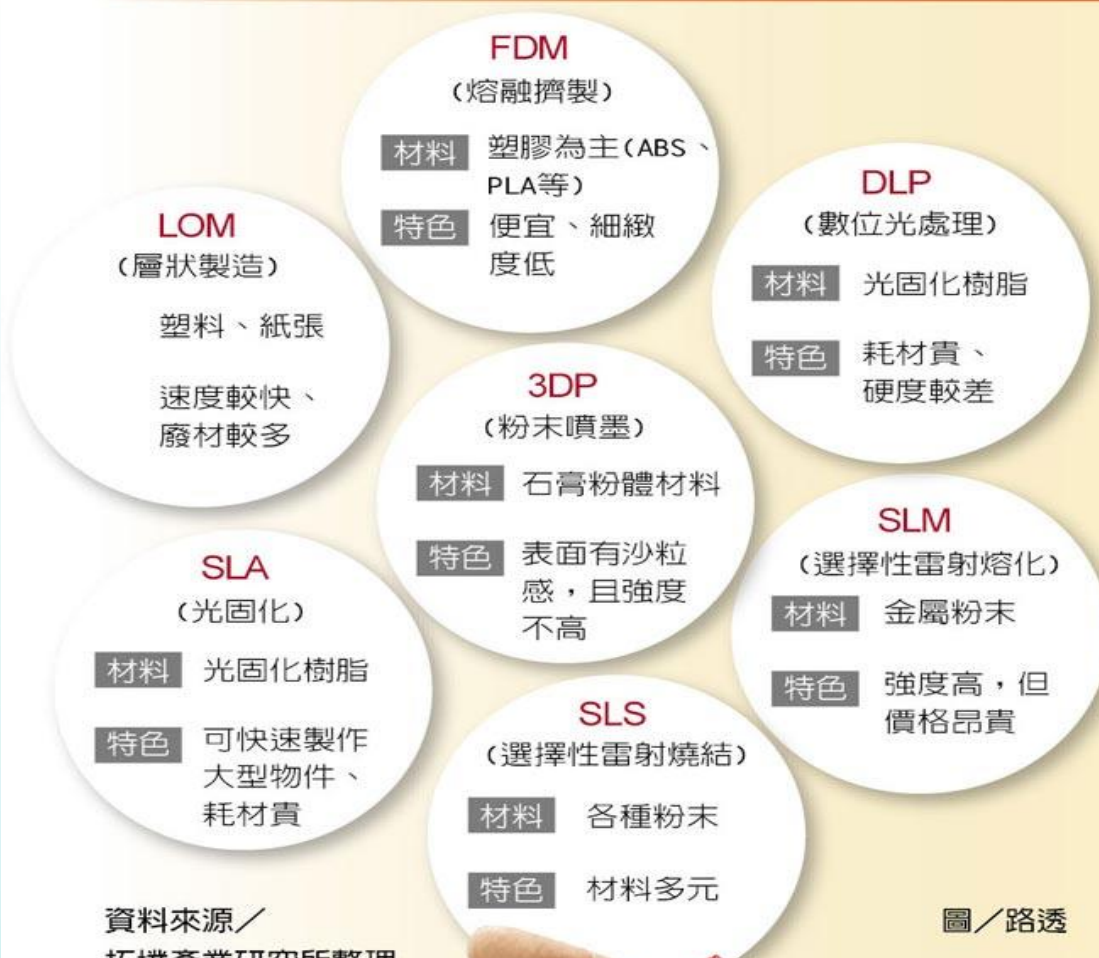



3D print technology

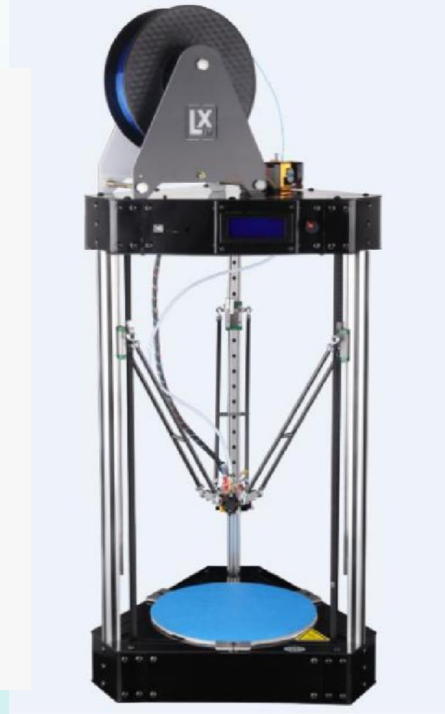

3D print technology

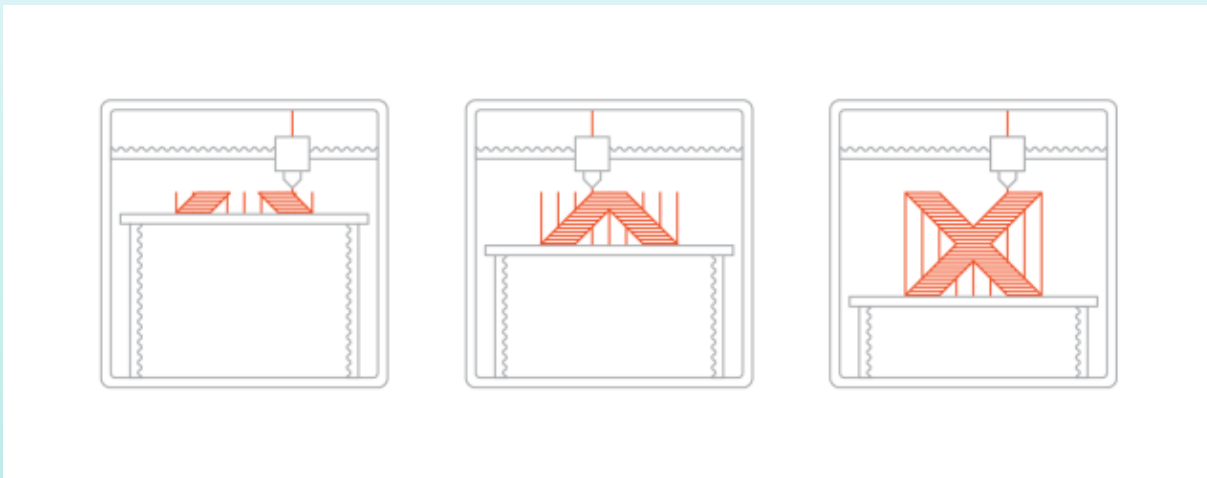
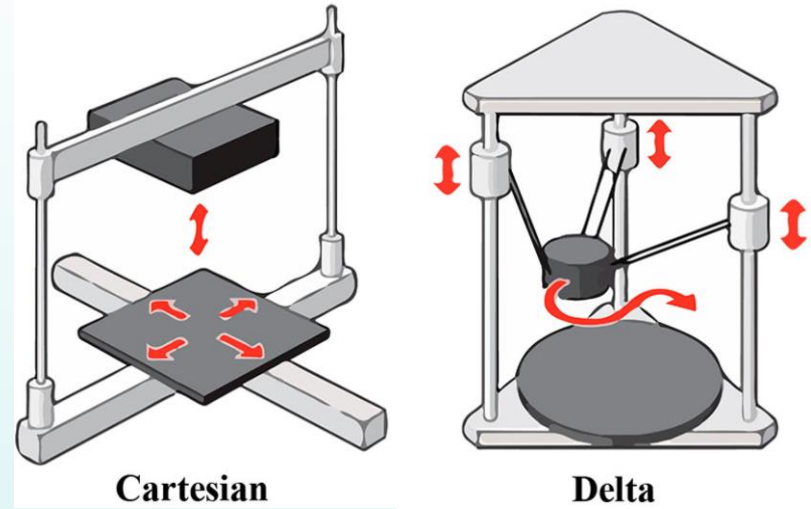
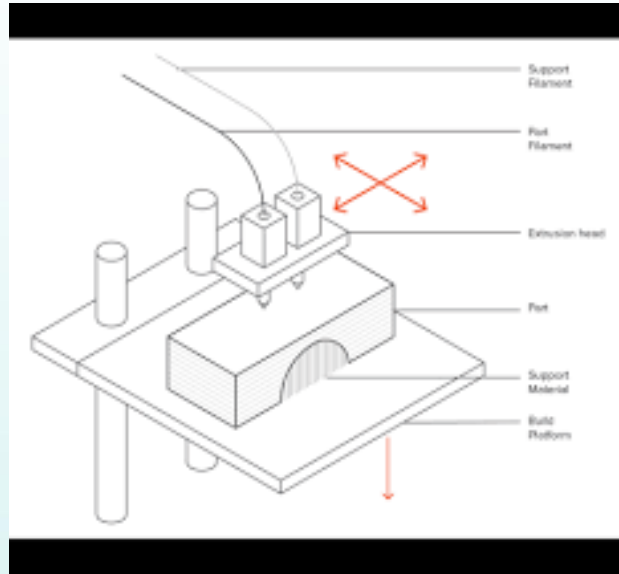

Type	Delta	Cartesian
Side		
Top		



3D drawing software

- SolidWorks
- Fusion 360
- CATIA

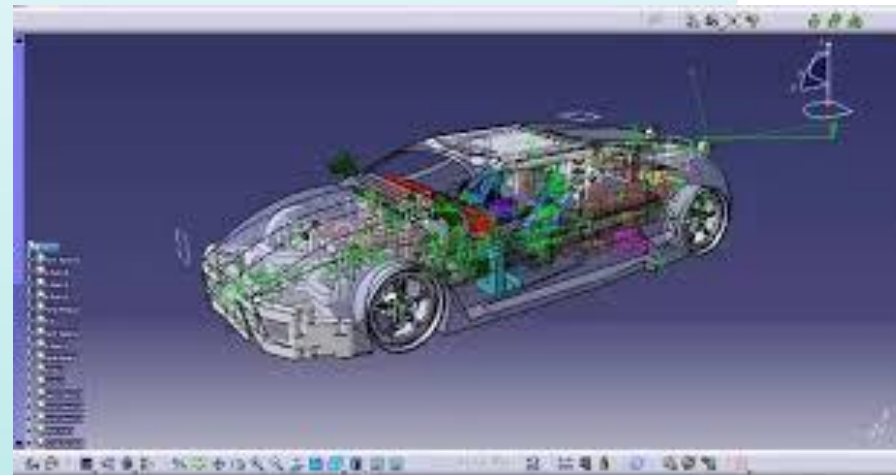
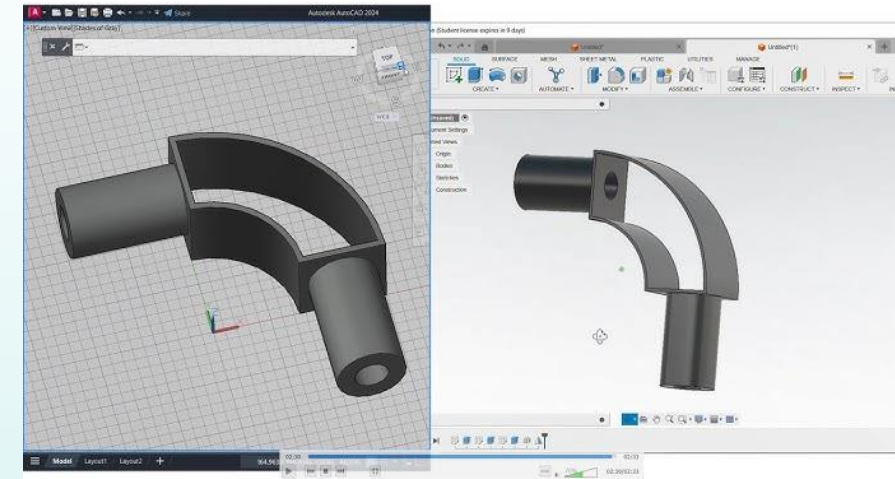
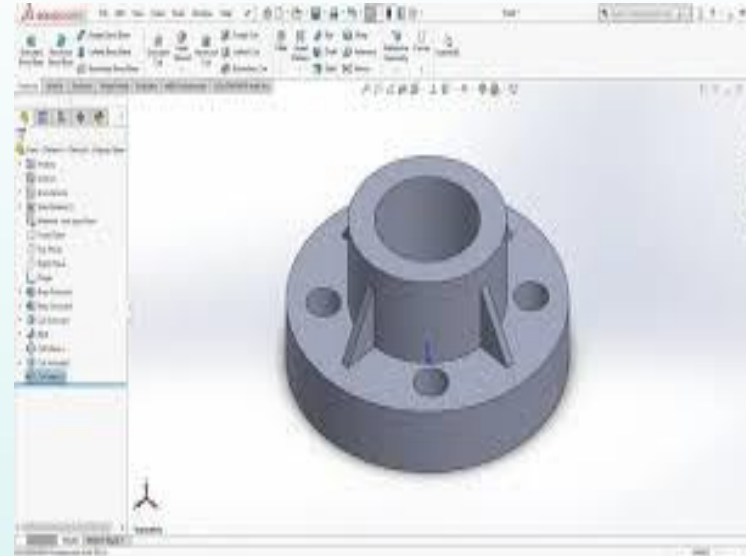



3D drawing software

Feature	Fusion 360	SolidWorks	CATIA
Surface Modeling	Basic, suitable for organic shapes	Excellent, suitable for most industrial products	Top-tier (Class-A), for aerospace and automotive use
Large Assembly	Performance drops significantly after 500+ parts	Stable performance with thousands of parts	Smooth operation even with tens of thousands of parts
Operating System	Windows & macOS	Only for Windows	Windows (Early support Unix)
Collaboration Method	Native cloud storage, simultaneous multi-user editing	Traditional file storage, requiring additional purchase of PDM/PLM	Powerful data management, integrated with 3DEXPERIENCE

3D print software

- Cura
- Meshmixer
- Sculptris
- Bambu Studio

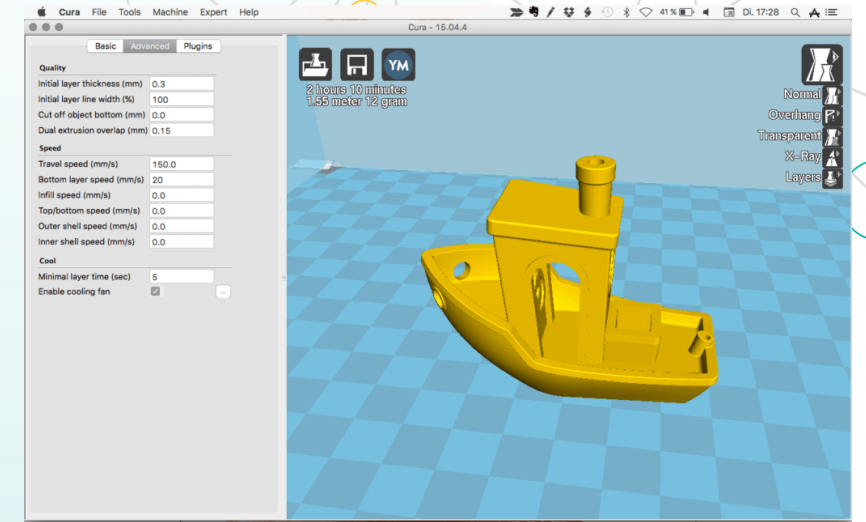
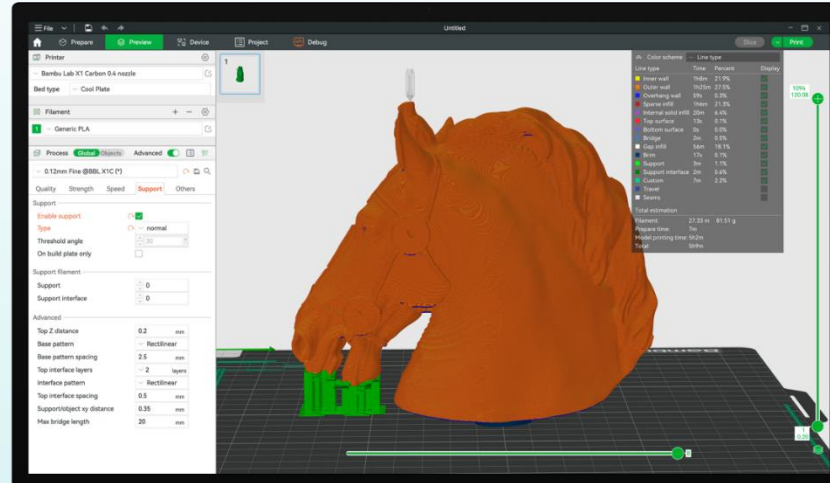

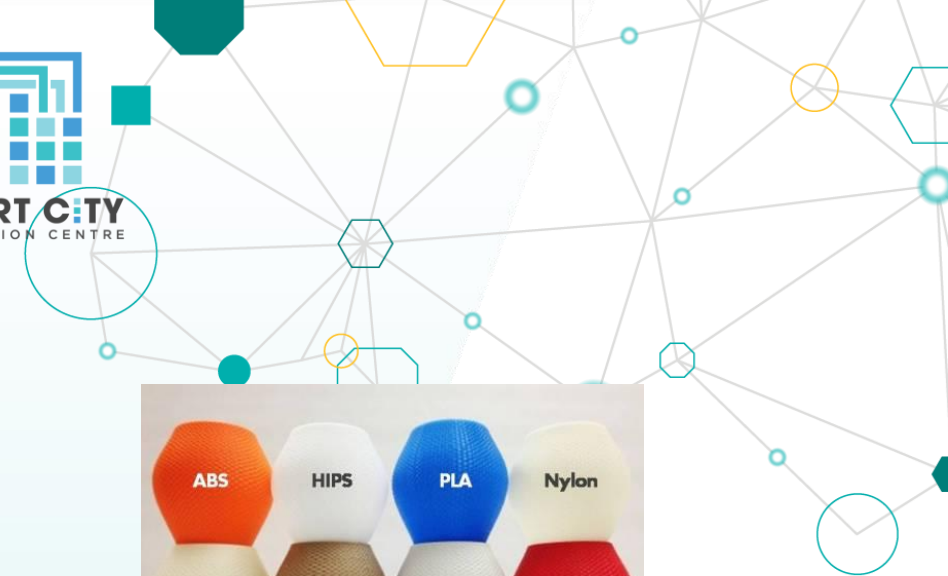

3D printing materials

Common plastic filament printing materials include:

- **PETG (230–270°C)**
 - Good strength and toughness, excellent chemical resistance, food-safe grade, easier to print than ABS.
- **PLA (180–200°C)**
 - Made from corn starch, biodegradable.
- **ABS (220–240°C)**
 - Strong and durable, with odour emitted during printing.
- **PVA (220–240°C)**
 - Water-soluble, used for printing support structures.
- **TPU (230–250°C)**
 - Soft, flexible, and highly elastic; suitable for phone cases, springs, and other rubber-like parts.





3D printing materials

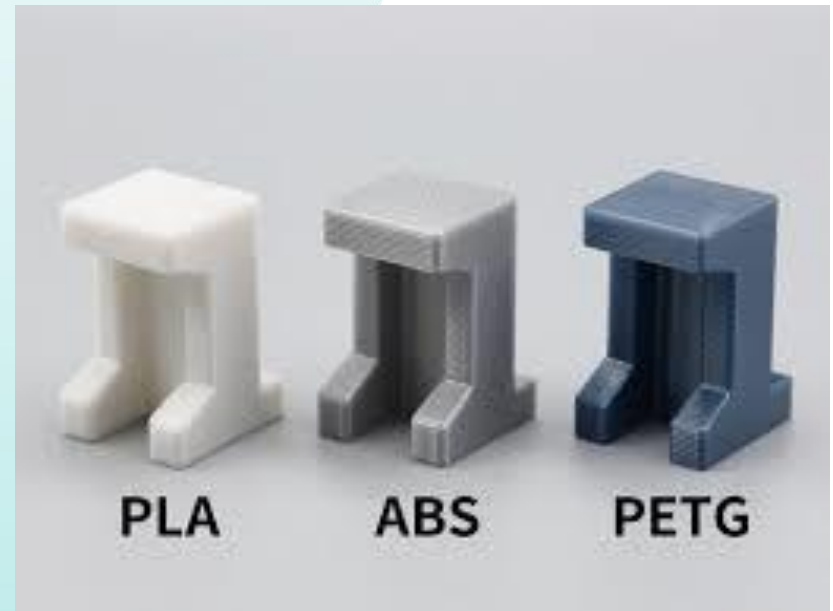
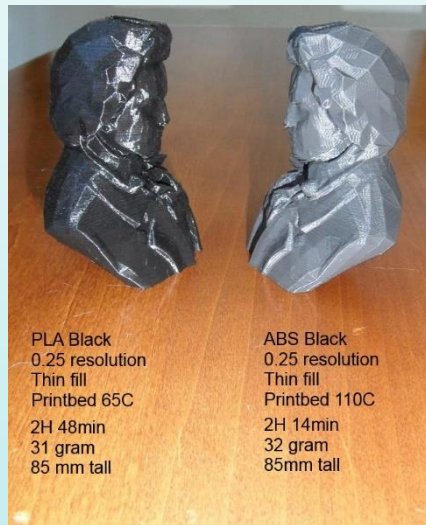

3D打印物料 (support)

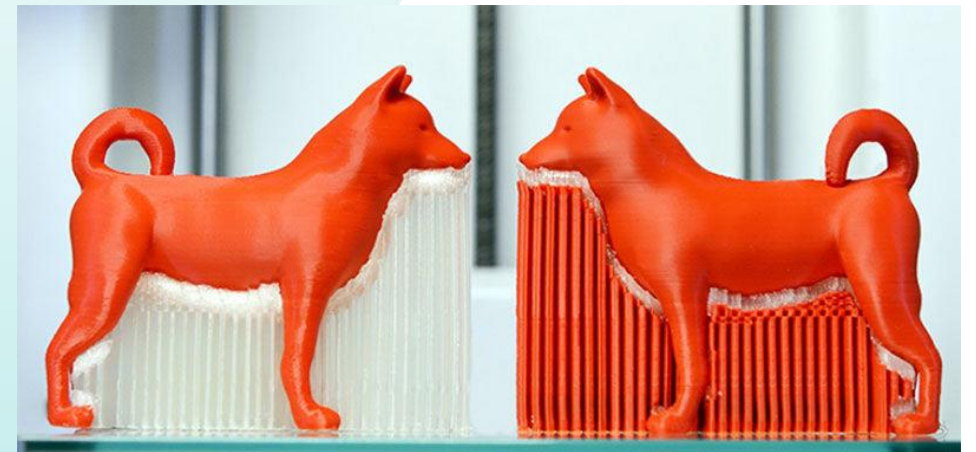
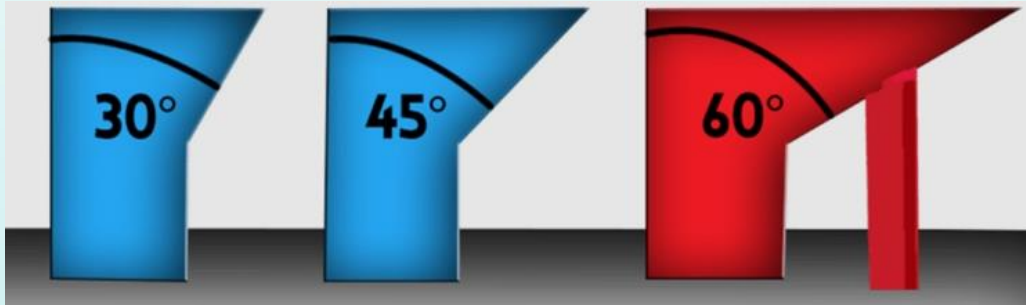
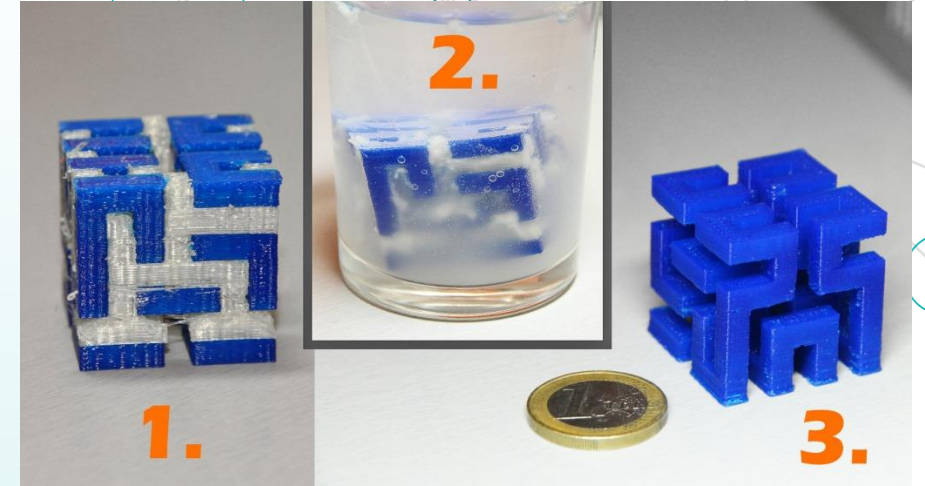



3D打印物料

Properties :

PLA (聚乳酸)

PETG (改性聚酯)

ABS (丙烯腈-丁二烯-苯乙烯)

Printing Notes /
Printing Precautions :

Almost no warping

Stringing issues need adjustme

Difficult, highly prone to warping;
requires enclosed chamber

Heat Resistance /
Temperature
Resistance :

Low (~60°C), may deform inside a
car in summer

Medium (~80°C), suitable for
most functional parts

High (~105°C), excellent thermal
stability

Mechanical Strength :

Hard and brittle, high tensile
strength but fragile

Good toughness, impact
resistance, chemical resistance

Good balance of rigidity and
toughness, wear-resistant

Weather Resistance :

Poor, easily affected by moisture
and UV degradation

Excellent, waterproof and UV
resistant

Fair; becomes brittle and fades
under long-term exposure

Odor:

Sweet smell, low VOCs (Volatile
Organic Compounds)

Very low odor

Pungent odor; releases toxic
styrene fumes



3D print technology

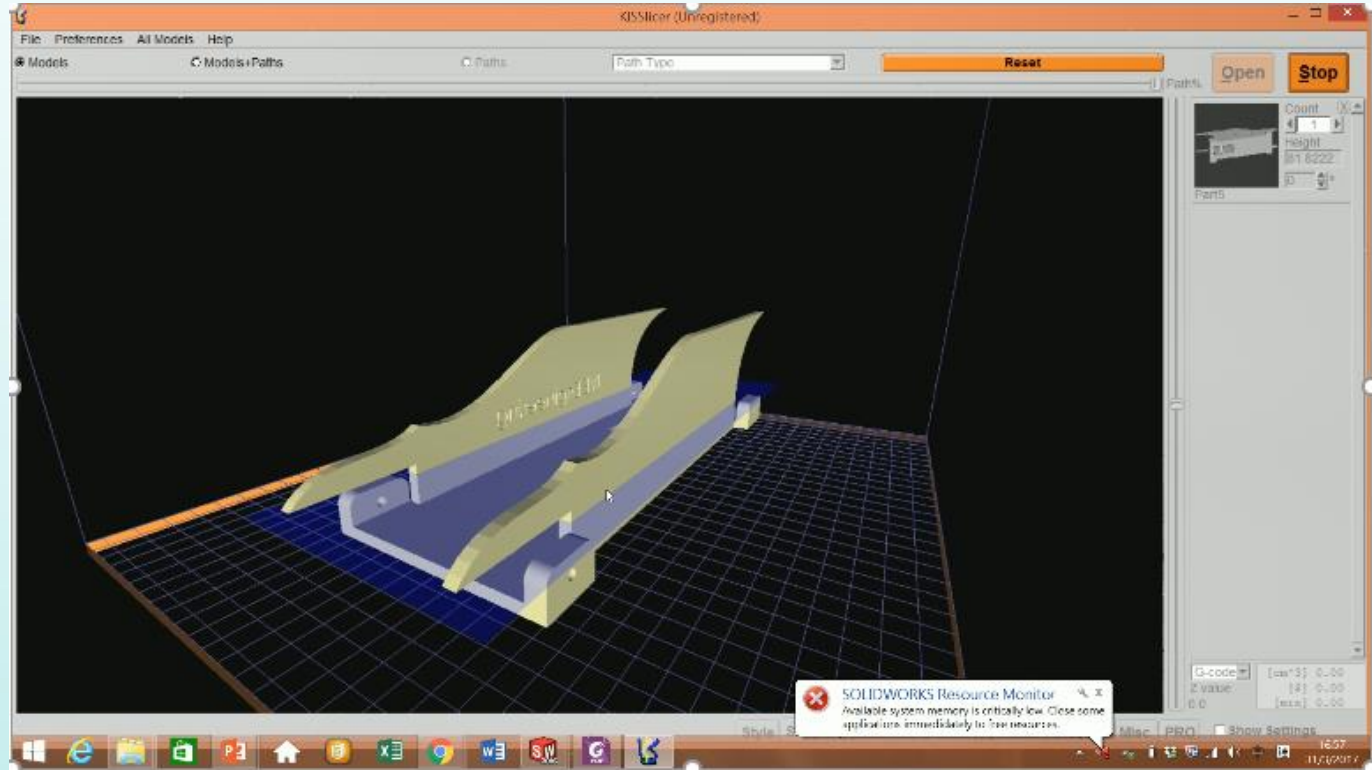

3D print technology

- 研究發展： **Research and Development (R&D)**
- 產品初模： **Product Prototyping**
- 歷史文物保存： **Historical Heritage Preservation**
- 建築工程： **Construction Engineering**
- 製造業： **Manufacturing**
- 汽車： **Automotive**



Strati – the world's first vehicle manufactured using 3D printing technology

3D print technology

- 打印速度：Printing speed
- 內壁厚度：Inner wall thickness
- 外層層數：Outer layer count
- 支撐位（cross/line）：Support structure (cross/line)
- 填充密度：Infill density

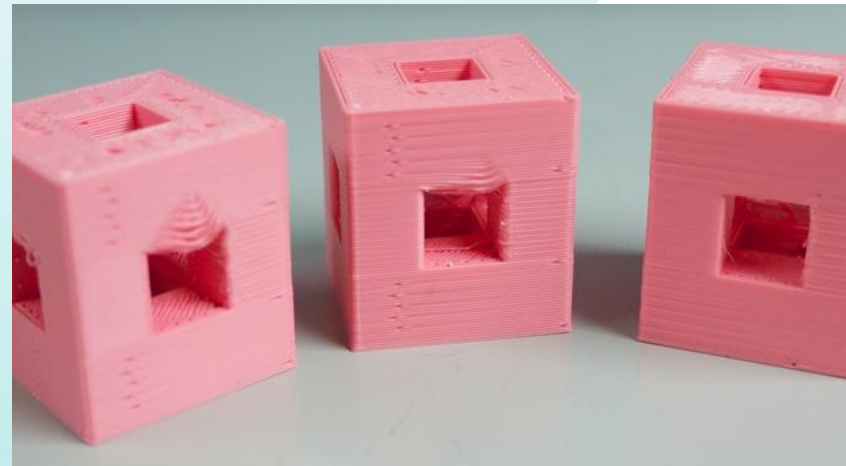



3D print technology

DeltaBot

Material: PLA
Profile: High Quality 0.06mm

Print Setup Recommended Custom

Quality

- Layer Height: 0.1 mm
- Initial Layer Height: 0.3 mm
- Line Width: 0.4 mm
 - Wall Line Width: 0.4 mm
 - Outer Wall Line Width: 0.4 mm
 - Inner Wall(s) Line Width: 0.4 mm
 - Top/Bottom Line Width: 0.4 mm
 - Infill Line Width: 0.4 mm
 - Support Line Width: 0.4 mm

Shell

- Wall Thickness: 0.8 mm
- Wall Line Count: 2
- Outer Wall Wipe Distance: 0.2 mm
- Top/Bottom Thickness: 0.8 mm

Infill

- Infill Density: 20 %

Material

- Printing Temperature: 200 °C
- Build Plate Temperature: 60 °C
- Diameter: 1.75 mm
- Flow: 100 %
- Enable Retraction:

Speed

- Print Speed: 50 mm/s
- Infill Speed: 80 mm/s
- Top/Bottom Speed: 15 mm/s
- Travel Speed: 120 mm/s

Ready to Save to Removable Drive

Save to Removable Drive

D_01_Body(NEW)
47.5 x 117.6 x 28.4 mm
05h 17min | 6.65 m / ~ 19 g

cura.



3D print technology

DeltaBot

Material: PLA
Profile: High Quality 0.06mm

Print Setup Recommended Custom

Walls

- Wall Thickness: 0.8 mm
- Wall Line Count: 2
- Outer Wall Wipe Distance: 0.2 mm
- Top/Bottom Thickness: 0.8 mm

Infill

- Infill Density: 20 %

Material

- Printing Temperature: 200 °C
- Build Plate Temperature: 60 °C
- Diameter: 1.75 mm
- Flow: 100 %
- Enable Retraction:

Speed

- Print Speed: 50 mm/s
- Infill Speed: 80 mm/s
- Top/Bottom Speed: 15 mm/s
- Travel Speed: 120 mm/s

Cooling

- Enable Print Cooling:

Support

- Enable Support:
- Support Placement: Everywhere

Build Plate Adhesion

- Build Plate Adhesion Type: Raft
- Raft Air Gap: 0.3 mm
- Initial Layer Z Overlap: 0.15 mm
- Raft Top Layers: 2

Ready to Save to Removable Drive

Save to Removable Drive

D_01_Body(NEW)
47.5 x 117.6 x 28.4 mm
05h 17min | 6.65 m / ~ 19 g



3D print technology

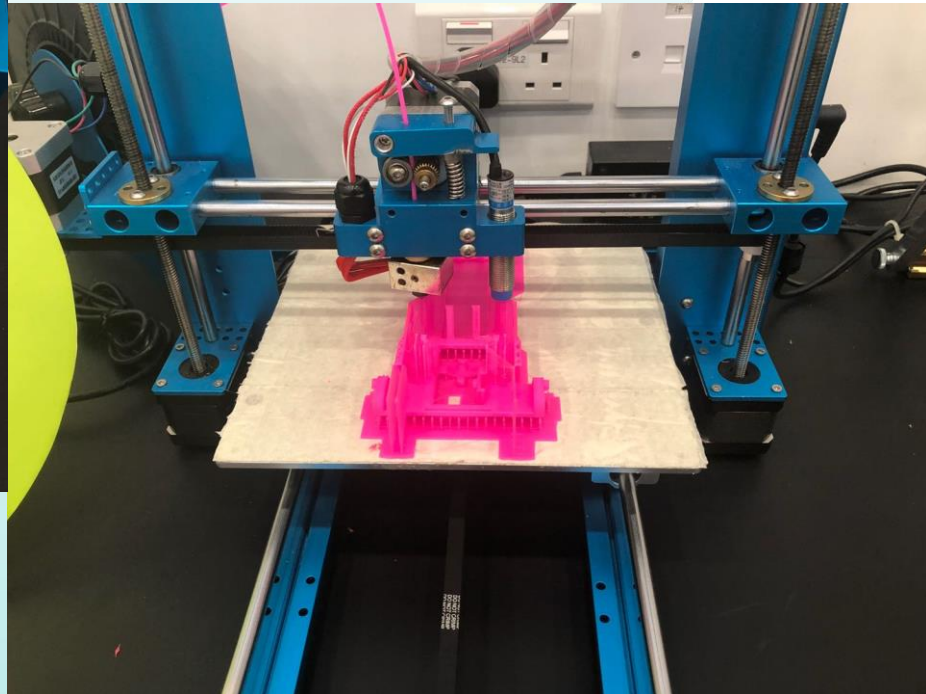
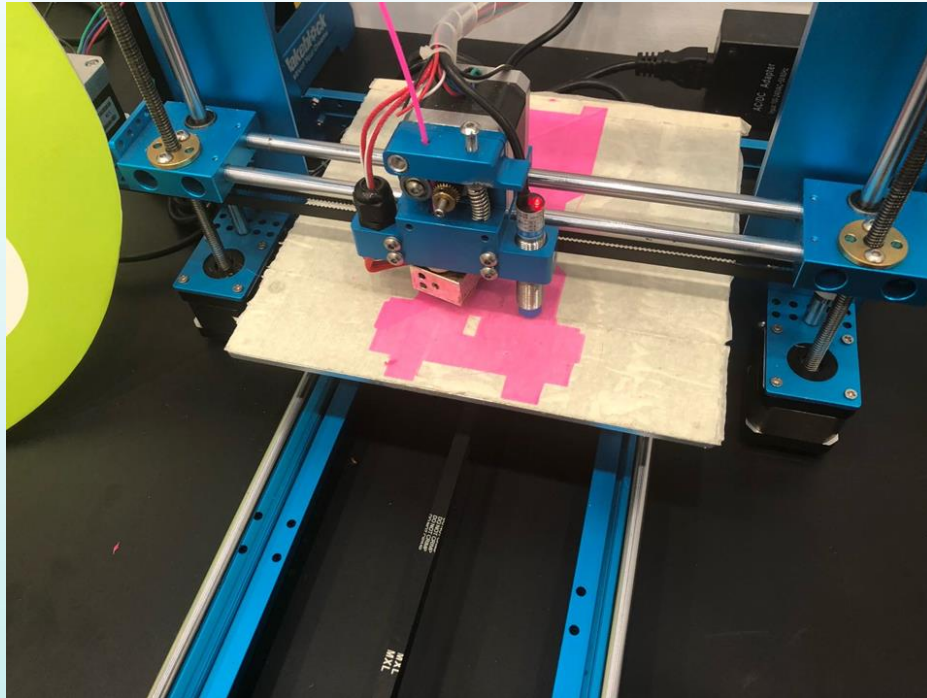

Chassis

Body size and shape

- Area
- Car shape

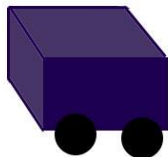
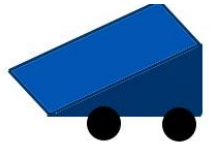

Material weight and strength

- PVC
- PLA
- wood
- Paper



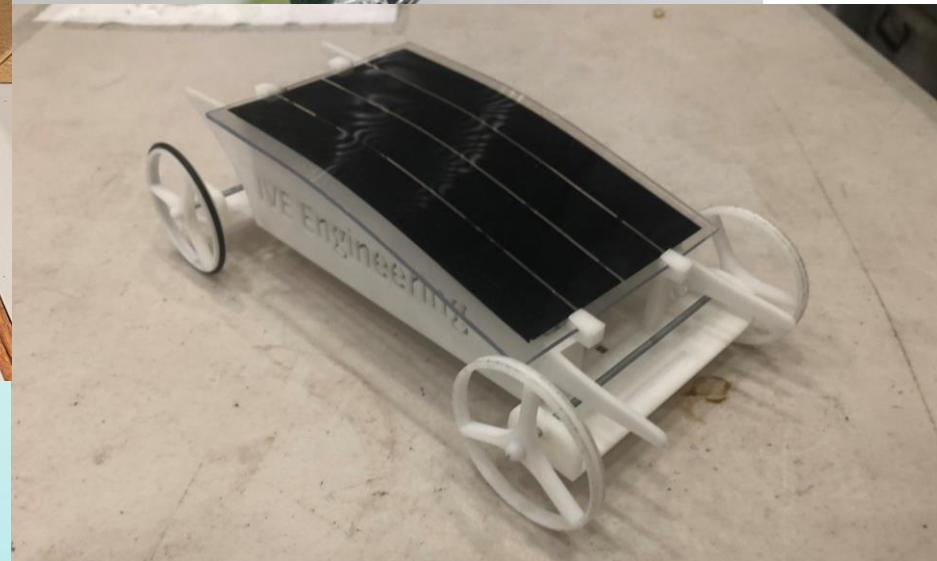
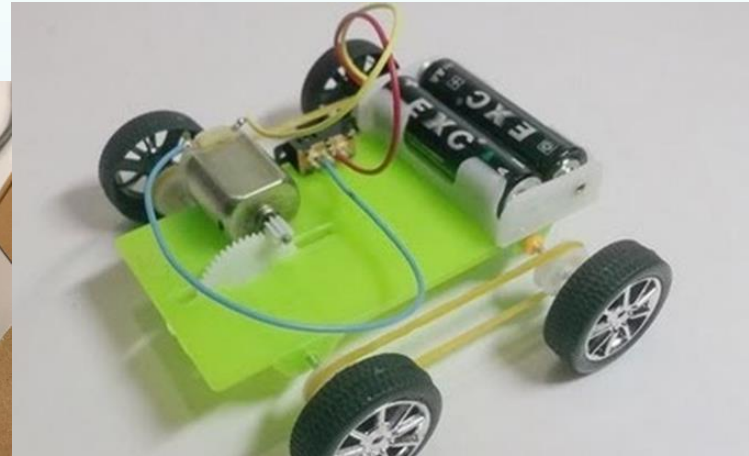
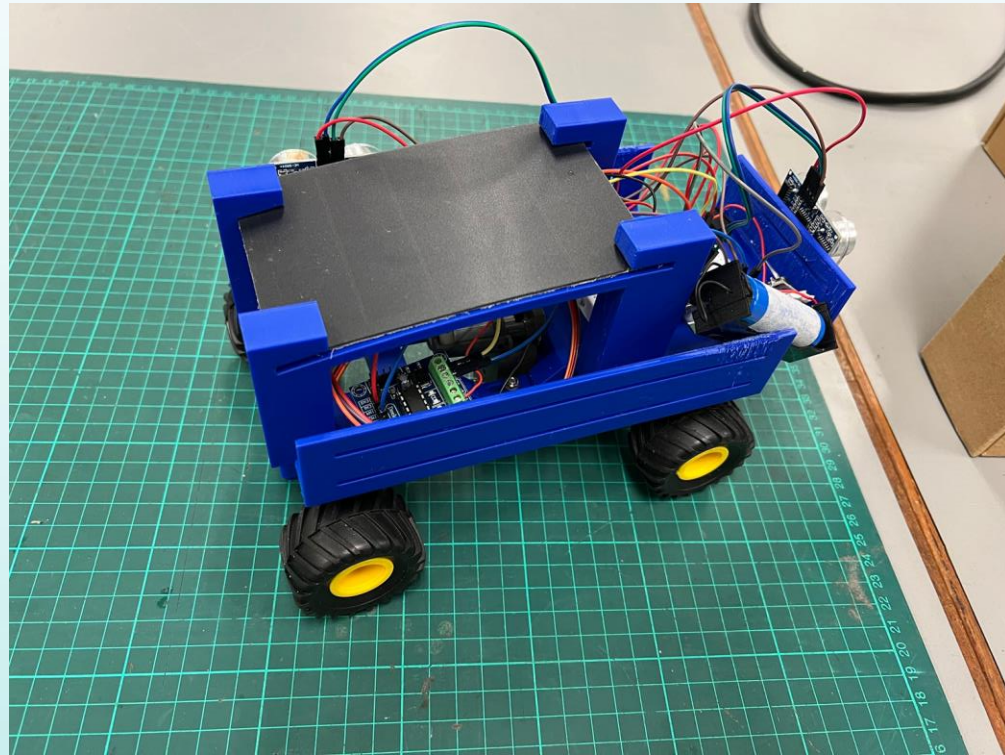

Design consideration

- 車身尺寸和形狀：Body size and shape
- 材料（重量）：Material (weight)
- 輪子尺寸和數字（3 輪 / 4 輪）：Wheel size and number (3 wheels / 4 wheels)
- 底盤結構（1 件 / 組零件）：Chassis structure (one-piece / assembly)

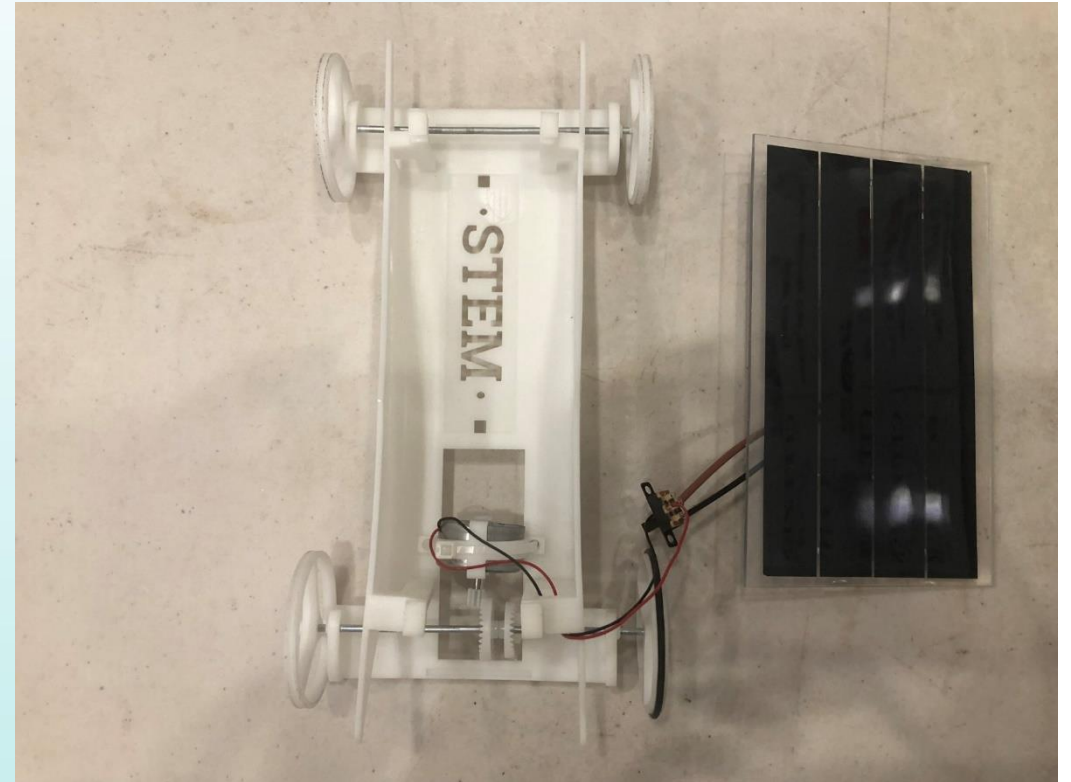

Powertrain

輪子尺寸和數字（3 輪 / 4 輪）：Wheel size and number (3 wheels / 4 wheels)

確定車輪尺寸：Determine wheel size

確保負載額定值：Ensure load rating

提高穩定性：Improve stability

速度需求（小輪子有助提升速度）：Speed requirement (smaller wheels help increase speed)

車輪重量：Wheel weight

燃料消耗和成本：Fuel consumption and cost

底盤結構（1 件 / 組零件）：Chassis structure (single-piece / assembly)

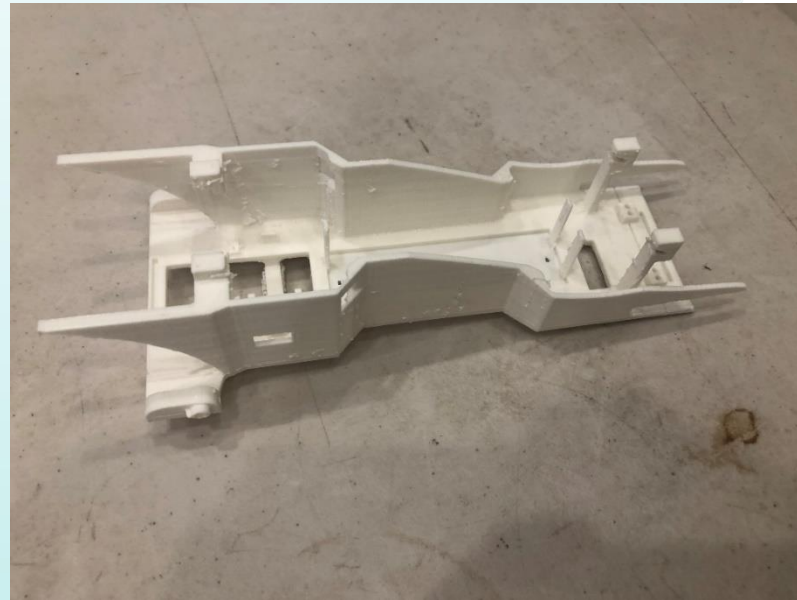

3D打印技術

小休



Powertrain

1. Powertrain system design
2. Circuit connection and welding assembly

Circuit design

- Battery
- Solar panel
- DC-DC boost converter
- Capacitor
- ESP32 control board
- Motor driver
- Power and steering motor



Solar energy

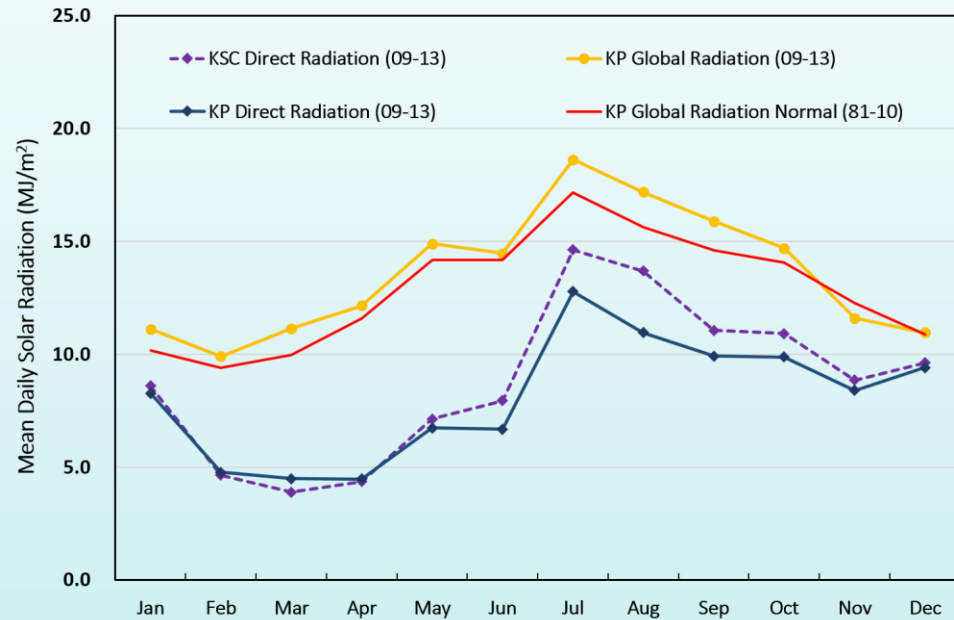

Monthly average daily solar radiation recorded at King's Park and Kau Sai Chau, Hong Kong, from 2009 to 2013

Global Horizontal Irradiation

South And Southeast Asia

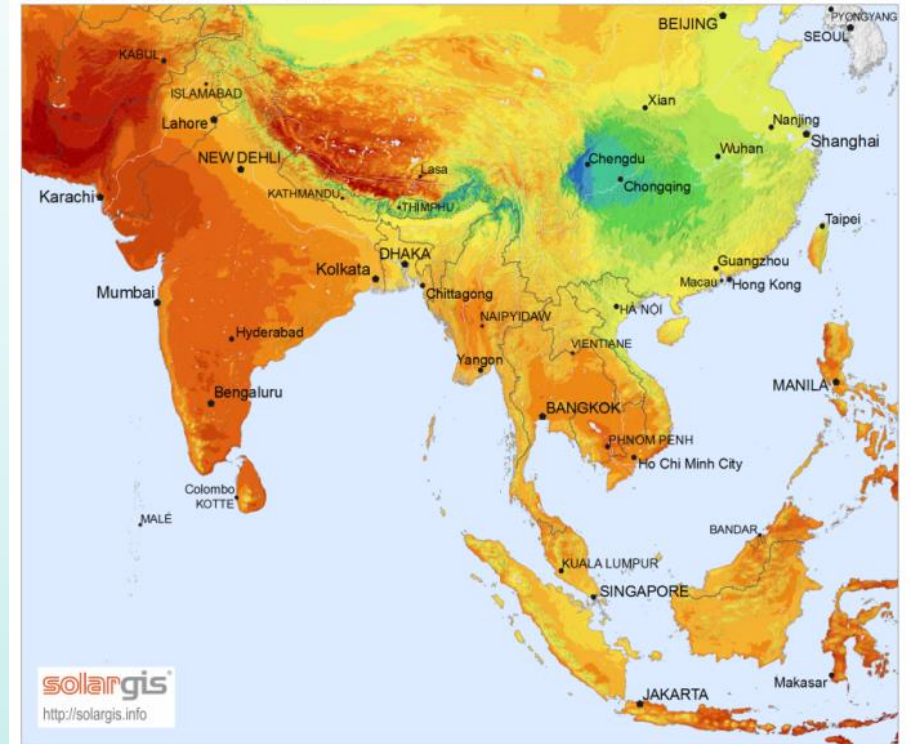

Average annual sum (1999-2011)
< 1000 1200 1400 1600 1800 2000 2200 > kWh/m²
SolarGIS © 2012 GeoModel Solar s.r.o.

Solar radiation recorded in Asian and Southeast Asian countries



Solar panel working principle

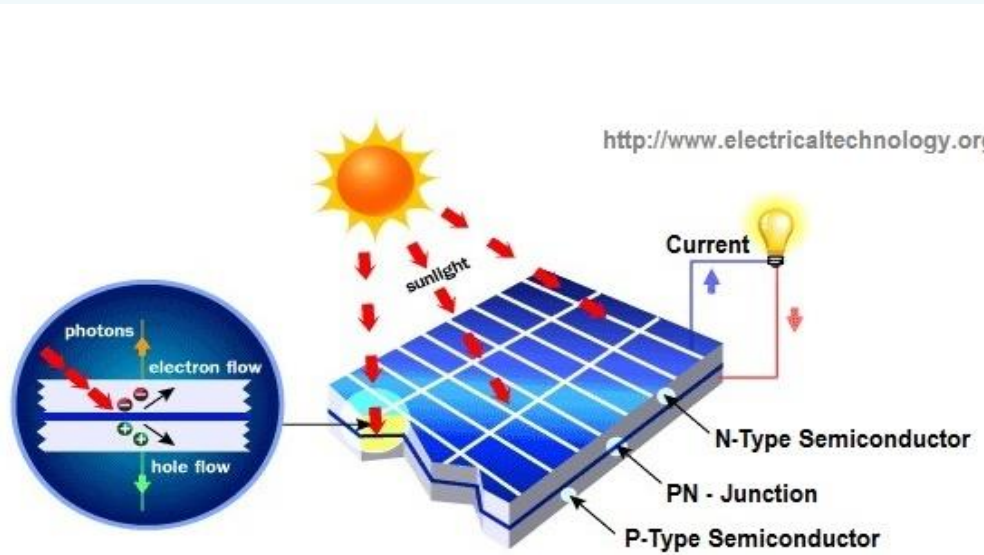

Basic Operating Principle of a Solar Cell

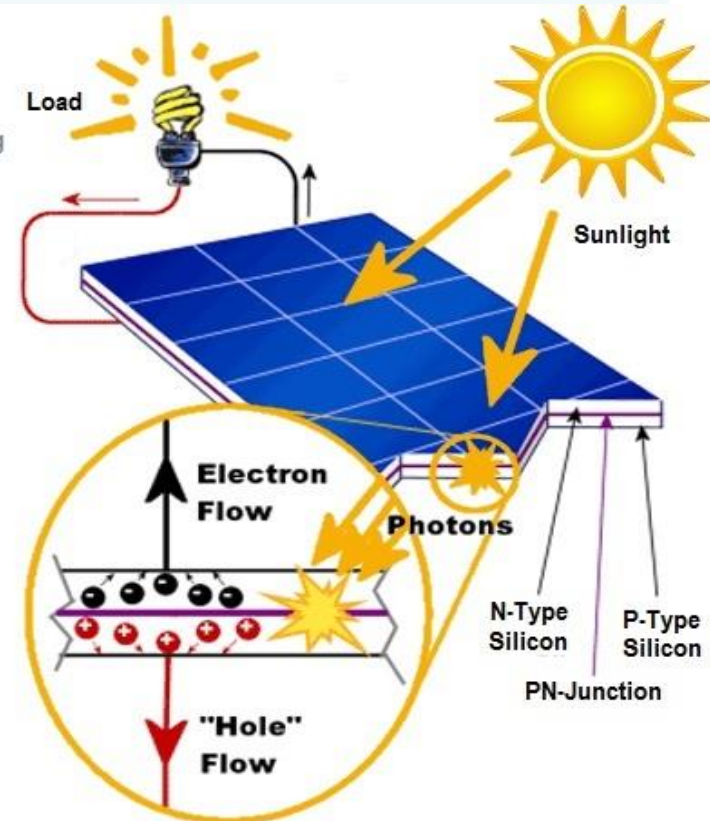

Powertrain



Solar panel

DC-DC converter

Circuit

Battery

Motor drive

Motor, and servo motor



Circuit components

Battery (NCR18650PF)

- Powers the electronic components on the vehicle
- Solar energy can be stored in the battery
- Avoid overcharging and moisture
- Do not use if the battery is swollen

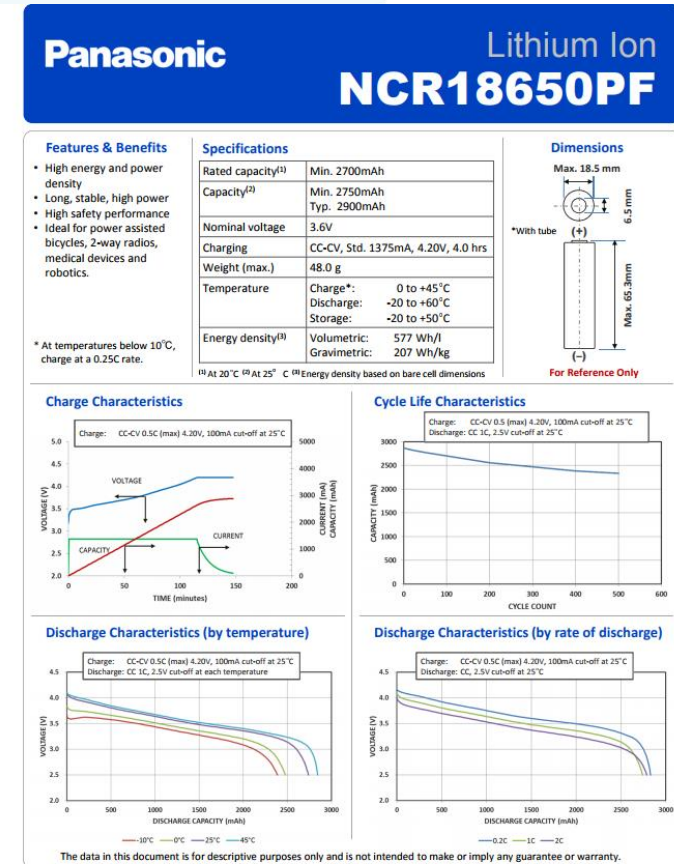



EV basic

DC-DC Converter

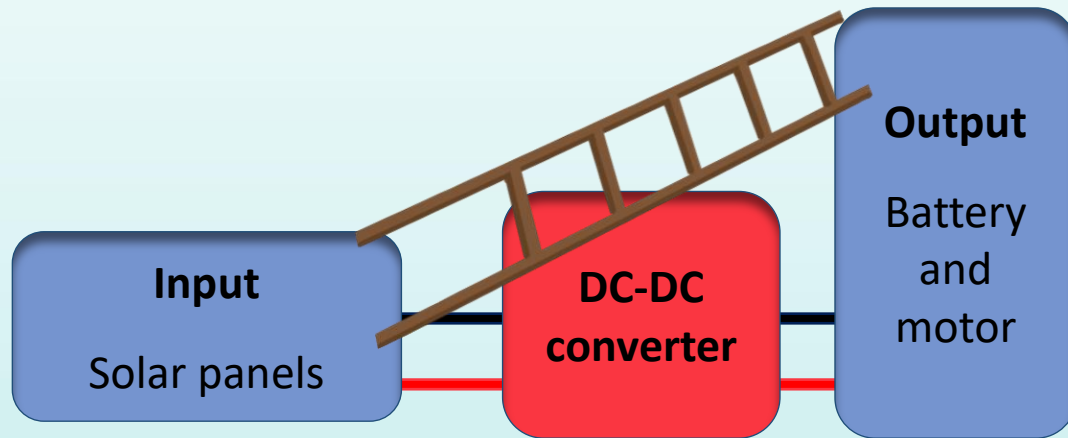

- It is a power conversion circuit that converts DC power into DC power of different voltages.
- A DC-DC converter allows the circuit voltage to be maintained within a certain range.



EV basic

DC-DC converter working principle

- A circuit that converts low voltage to high voltage.

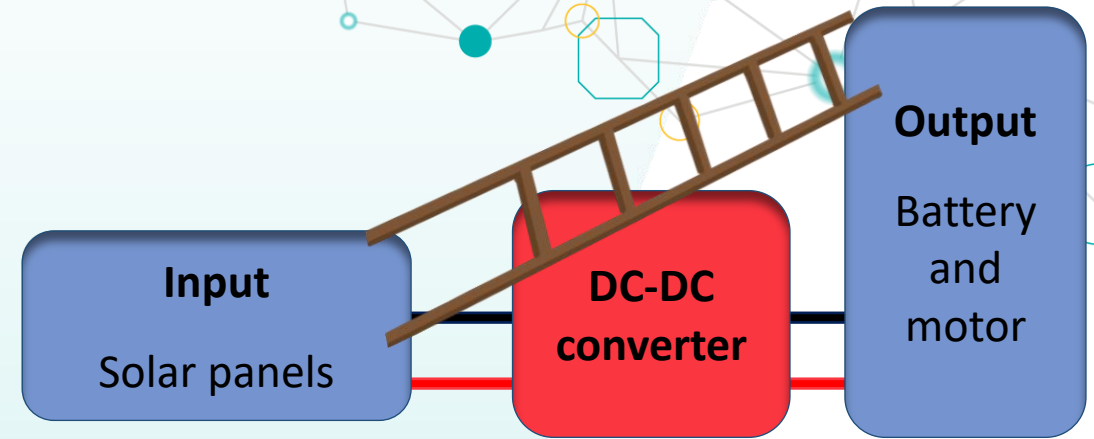

Discontinuous Conduction Mode (DCM) circuit

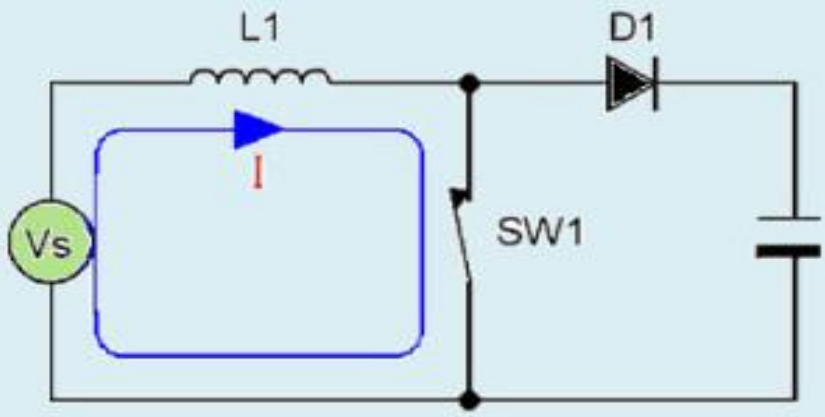

Continuous Conduction Mode (CCM) circuit

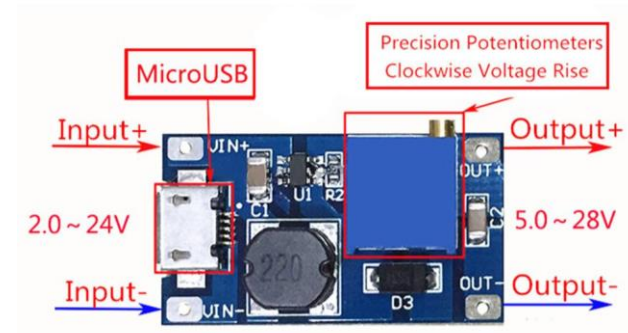
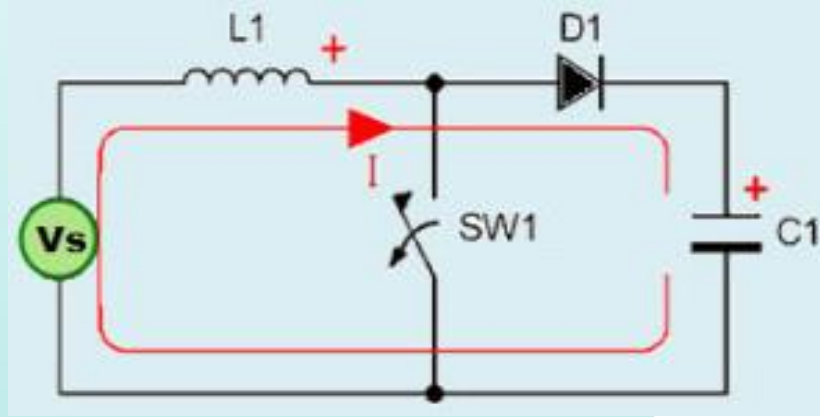



EV basic

Motor

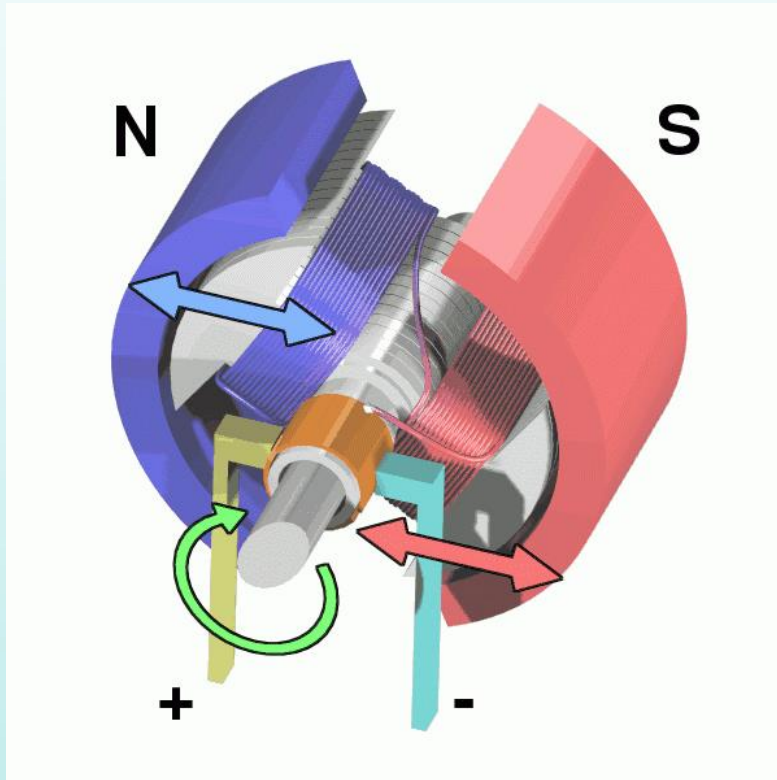

- A DC motor is a motor driven by direct current. Most commonly, it rotates using the force generated by a magnetic field.
- Almost all DC motors have a similar mechanism, which periodically changes the direction of the current in the motor, either electromechanically or electronically.

ESP32 Module

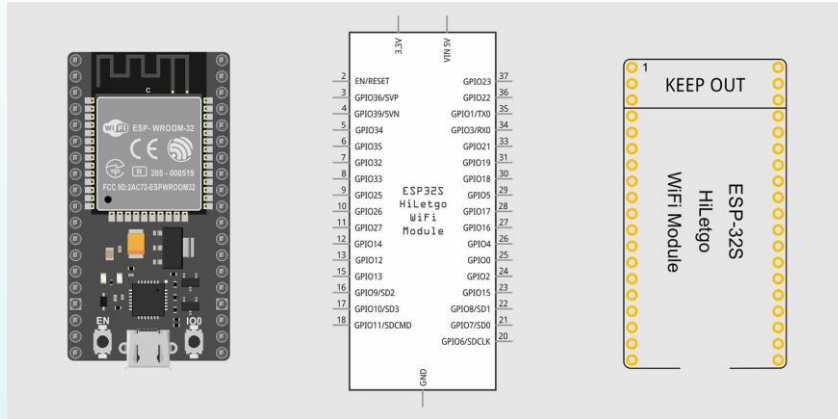

Solar panel

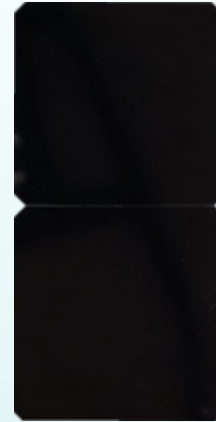

DC-DC Converter



Ultrasonic sensor



Motor, Servo motor, motor drive



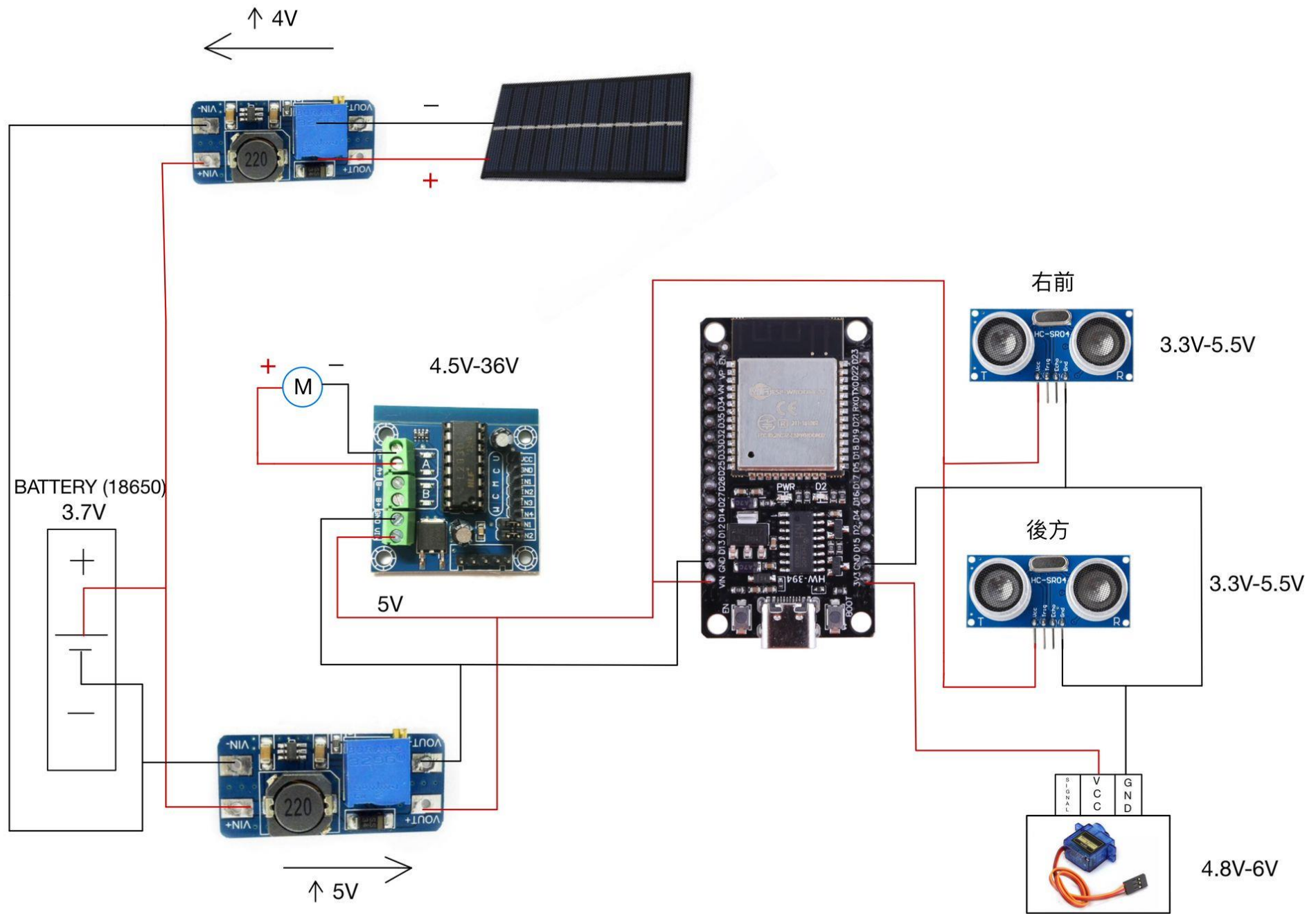



Parking principle

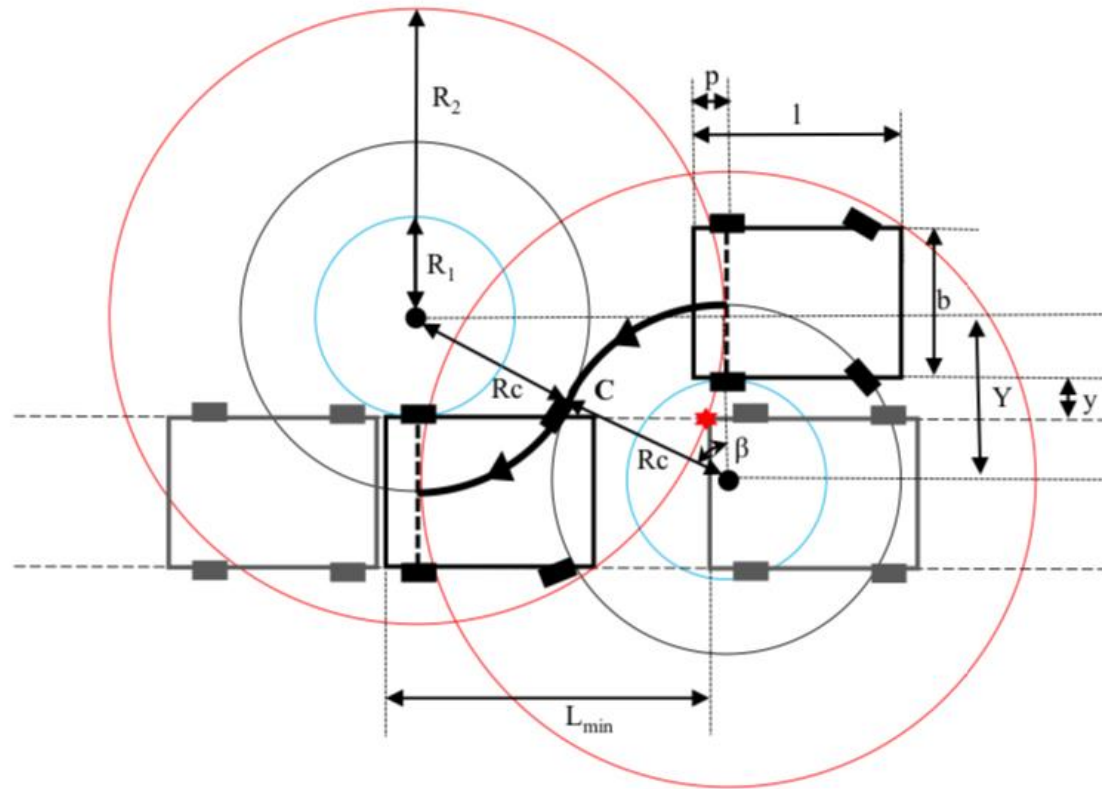



Autoparking





Competition track



Track

- Based on the Hidden Valley Raceway, the qualifying track for the Bridgestone World Solar Challenge.
- The track is approximately 4,500 millimeters long and 2,000 millimeters wide.

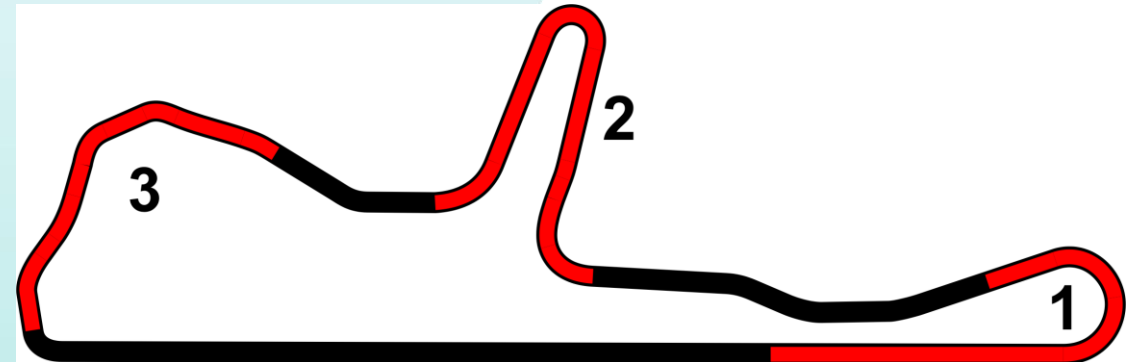

Auto parking

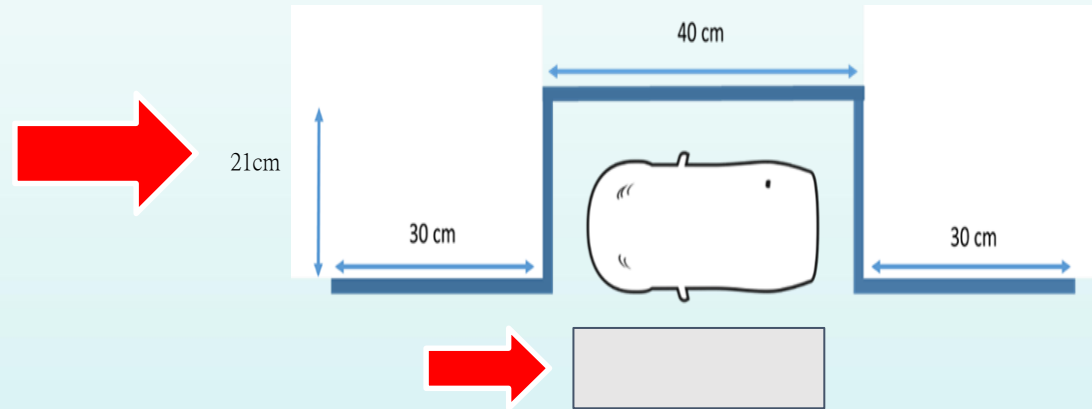

- The solar-powered remote-controlled car must first complete **one full lap of the track** before performing the parking maneuver.
- The parking space is marked with a rectangular box;
- the car is considered **successfully parked only if it is fully inside the box** (must not cross the lines, and no part of the body may protrude).
- After completing the lap, you may **reposition the solar-powered RC car to the designated position [P]**.



SOPHIE



Thank you

